



**BASE**

Glass-fibre reinforced polyamide based (PA) special conductive technopolymer, black colour, matte finish.

Surface resistivity =  $10^3 \Omega$  (ASTM D257 measuring method).

Volume resistivity =  $10^3 \Omega\text{cm}$  (ASTM D257 measuring method).

**ARTICULATED STEM**

Threaded AISI 304 stainless steel with regulation hexagon.

**STANDARD EXECUTIONS**

- **LV.A-SST-ESC-C**: without no-slip disk.
- **LV.A-AS-SST-ESD-C**: with NBR conductive rubber, hardness 70 Shore A, supplied assembled.

Surface resistivity =  $10^3 \Omega$  (ASTM D257 measuring method).

Volume resistivity =  $10^3 \Omega\text{cm}$  (ASTM D257 measuring method).

**FEATURES AND APPLICATIONS**

The special conductive technopolymer (ESD-C Electrostatic Discharge Conductive) prevents the accumulation of electrostatic charge.

The bases are suitable for "ESD PROTECTED AREA" (EPA) where components, which are susceptible to electrostatic discharges, are handled. The (ESD-C) indelibly printed mark on the surface of the levelling elements bases identifies the particular conductive features of the material according to EN 100015/1 and IEC 61340-5-1.

The particular assembling system of the no-slip disk to the base assures a perfect anchoring, preventing separation even in case of impact during transport or of adhesion (sticking) to the floor (see No-slip disks on page 979).

**ORDER INFORMATION**

The levelling elements are supplied unassembled to make carriage and storage easier. The components (base and stem) are supplied in separate packing: less volume taken and better protection from scratches and dirt.

To order bases and stems separately, see:

- table of possible combinations Bases/Stems (see page 984)
- the codes of the Bases (see page 838)
- the codes of the Stems (see page 986).

**ACCESSORIES ON REQUEST**

AISI 304 stainless steel nut (see Nuts NT. on page 979).



ELESA Original design

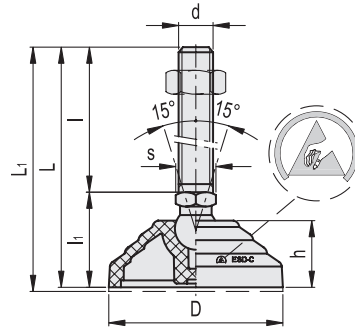

Conversion Table	
1 mm = 0.039 inch	
D	
mm	inch
60	2.36
70	2.76
80	3.15
100	3.94
125	4.92

**LV.A-SST-ESD-C**

**LV.A-AS-SST-ESD-C**



Code	Description	Code	Description	D	d	L	L1#	l	l1	h	s	Articulation $\emptyset$	Max. limit static load* [N]	#	
323121-ESD	LV.A-60-14-SST-M8x43-ESD-C	327121-ESD	LV.A-60-14-AS-SST-M8x43-ESD-C	60	M8	76	79	43	33	24	14	14	14000	63	82
323125-ESD	LV.A-60-14-SST-M8x68-ESD-C	327125-ESD	LV.A-60-14-AS-SST-M8x68-ESD-C	60	M8	101	104	68	33	24	14	14	14000	75	94
323221-ESD	LV.A-60-14-SST-M10x43-ESD-C	327221-ESD	LV.A-60-14-AS-SST-M10x43-ESD-C	60	M10	76	79	43	33	24	14	14	14000	72	91
323225-ESD	LV.A-60-14-SST-M10x68-ESD-C	327225-ESD	LV.A-60-14-AS-SST-M10x68-ESD-C	60	M10	101	104	68	33	24	14	14	14000	85	104
323231-ESD	LV.A-60-14-SST-M10x98-ESD-C	327231-ESD	LV.A-60-14-AS-SST-M10x98-ESD-C	60	M10	131	134	98	33	24	14	14	14000	99	118
323321-ESD	LV.A-60-14-SST-M12x43-ESD-C	327321-ESD	LV.A-60-14-AS-SST-M12x43-ESD-C	60	M12	76	79	43	33	24	14	14	14000	82	101
323325-ESD	LV.A-60-14-SST-M12x68-ESD-C	327325-ESD	LV.A-60-14-AS-SST-M12x68-ESD-C	60	M12	101	104	68	33	24	14	14	14000	100	119
323331-ESD	LV.A-60-14-SST-M12x98-ESD-C	327331-ESD	LV.A-60-14-AS-SST-M12x98-ESD-C	60	M12	131	134	98	33	24	14	14	14000	122	141
323421-ESD	LV.A-60-14-SST-M14x68-ESD-C	327421-ESD	LV.A-60-14-AS-SST-M14x68-ESD-C	60	M14	101	104	68	33	24	14	14	14000	123	142
323431-ESD	LV.A-60-14-SST-M14x98-ESD-C	327431-ESD	LV.A-60-14-AS-SST-M14x98-ESD-C	60	M14	131	134	98	33	24	14	14	14000	144	163
323441-ESD	LV.A-60-14-SST-M14X148-ESD-C	327441-ESD	LV.A-60-14-AS-SST-M14X148-ESD-C	60	M14	181	184	148	33	24	14	14	14000	227	246
323521-ESD	LV.A-60-14-SST-M16x68-ESD-C	327521-ESD	LV.A-60-14-AS-SST-M16x68-ESD-C	60	M16	101	104	68	33	24	16	14	14000	145	164
323525-ESD	LV.A-60-14-SST-M16x108-ESD-C	327525-ESD	LV.A-60-14-AS-SST-M16x108-ESD-C	60	M16	141	144	108	33	24	16	14	14000	199	218
323541-ESD	LV.A-60-14-SST-M16x148-ESD-C	327541-ESD	LV.A-60-14-AS-SST-M16x148-ESD-C	60	M16	181	184	148	33	24	16	14	14000	252	271
323561-ESD	LV.A-60-14-SST-M16x168-ESD-C	327561-ESD	LV.A-60-14-AS-SST-M16x168-ESD-C	60	M16	201	204	168	33	24	16	14	14000	279	298

\* The max static load is the value above which the load applied to the element may cause some plastic material breakage, in particular conditions of use. Obviously, a factor that takes into consideration the importance and the safety level of the specific application must be applied to this value.

# Data with no-slip disk mounted.



Levelling elements and supports



Levelling elements and supports

Conversion Table	
1 mm = 0.039 inch	
mm	inch
60	2.36
70	2.76
80	3.15
100	3.94
125	4.92

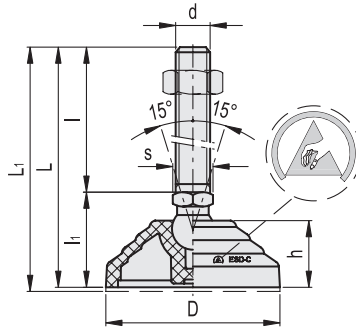

LVA-SST-ESD-C

LVA-AS-SST-ESD-C

INOX STAINLESS STEEL METRIC

Code	Description	Code	Description	D	d	L	L1#	l	li	h	s	Articulation ∅	Max. limit static load* [N]	⚖️	⚖️#
323621-ESD	LVA-60-24-SST-M16x58-ESD-C	327621-ESD	LVA-60-24-AS-SST-M16x58-ESD-C	60	M16	101	104	58	43	24	24	24	18000	208	227
323625-ESD	LVA-60-24-SST-M16x98-ESD-C	327625-ESD	LVA-60-24-AS-SST-M16x98-ESD-C	60	M16	141	144	98	43	24	24	24	18000	260	279
323641-ESD	LVA-60-24-SST-M16x138-ESD-C	327641-ESD	LVA-60-24-AS-SST-M16x138-ESD-C	60	M16	181	184	138	43	24	24	24	18000	311	330
323661-ESD	LVA-60-24-SST-M16x158-ESD-C	327661-ESD	LVA-60-24-AS-SST-M16x158-ESD-C	60	M16	201	204	158	43	24	24	24	18000	339	358
323725-ESD	LVA-60-24-SST-M20x98-ESD-C	327725-ESD	LVA-60-24-AS-SST-M20x98-ESD-C	60	M20	141	144	98	43	24	24	24	18000	332	351
323741-ESD	LVA-60-24-SST-M20x138-ESD-C	327741-ESD	LVA-60-24-AS-SST-M20x138-ESD-C	60	M20	181	184	138	43	24	24	24	18000	412	431
323761-ESD	LVA-60-24-SST-M20x158-ESD-C	327761-ESD	LVA-60-24-AS-SST-M20x158-ESD-C	60	M20	201	204	158	43	24	24	24	18000	452	471
323781-ESD	LVA-60-24-SST-M20x198-ESD-C	327781-ESD	LVA-60-24-AS-SST-M20x198-ESD-C	60	M20	241	244	198	43	24	24	24	18000	537	556
323825-ESD	LVA-60-24-SST-M24x98-ESD-C	327825-ESD	LVA-60-24-AS-SST-M24x98-ESD-C	60	M24	141	144	98	43	24	24	24	18000	432	451
323861-ESD	LVA-60-24-SST-M24x158-ESD-C	327861-ESD	LVA-60-24-AS-SST-M24x158-ESD-C	60	M24	201	204	158	43	24	24	24	18000	607	626
323881-ESD	LVA-60-24-SST-M24x198-ESD-C	327881-ESD	LVA-60-24-AS-SST-M24x198-ESD-C	60	M24	241	244	198	43	24	24	24	18000	728	747
324005-ESD	LVA-70-14-SST-M8x43-ESD-C	328005-ESD	LVA-70-14-AS-SST-M8x43-ESD-C	70	M8	71	74	43	28	19	14	14	14000	61	81
324011-ESD	LVA-70-14-SST-M8x68-ESD-C	328011-ESD	LVA-70-14-AS-SST-M8x68-ESD-C	70	M8	96	99	68	28	19	14	14	14000	73	93
324021-ESD	LVA-70-14-SST-M10x43-ESD-C	328021-ESD	LVA-70-14-AS-SST-M10x43-ESD-C	70	M10	71	74	43	28	19	14	14	14000	70	90
324025-ESD	LVA-70-14-SST-M10x68-ESD-C	328025-ESD	LVA-70-14-AS-SST-M10x68-ESD-C	70	M10	96	99	68	28	19	14	14	14000	84	103
324031-ESD	LVA-70-14-SST-M10x98-ESD-C	328031-ESD	LVA-70-14-AS-SST-M10x98-ESD-C	70	M10	126	129	98	28	19	14	14	14000	97	117
324061-ESD	LVA-70-14-SST-M12x43-ESD-C	328061-ESD	LVA-70-14-AS-SST-M12x43-ESD-C	70	M12	71	74	43	28	19	14	14	14000	80	100
324065-ESD	LVA-70-14-SST-M12x68-ESD-C	328065-ESD	LVA-70-14-AS-SST-M12x68-ESD-C	70	M12	96	99	68	28	19	14	14	14000	98	118
324071-ESD	LVA-70-14-SST-M12x98-ESD-C	328071-ESD	LVA-70-14-AS-SST-M12x98-ESD-C	70	M12	126	129	98	28	19	14	14	14000	120	140
324075-ESD	LVA-70-14-SST-M14x68-ESD-C	328075-ESD	LVA-70-14-AS-SST-M14x68-ESD-C	70	M14	96	99	68	28	19	14	14	14000	121	141
324081-ESD	LVA-70-14-SST-M14x98-ESD-C	328081-ESD	LVA-70-14-AS-SST-M14x98-ESD-C	70	M14	126	129	98	28	19	14	14	14000	142	162
324085-ESD	LVA-70-14-SST-M14x148-ESD-C	328085-ESD	LVA-70-14-AS-SST-M14x148-ESD-C	70	M14	176	179	148	28	19	14	14	14000	225	245
324101-ESD	LVA-70-14-SST-M16x68-ESD-C	328101-ESD	LVA-70-14-AS-SST-M16x68-ESD-C	70	M16	96	99	68	28	19	16	14	14000	143	163
324105-ESD	LVA-70-14-SST-M16x108-ESD-C	328105-ESD	LVA-70-14-AS-SST-M16x108-ESD-C	70	M16	136	139	108	28	19	16	14	14000	197	217
324111-ESD	LVA-70-14-SST-M16x148-ESD-C	328111-ESD	LVA-70-14-AS-SST-M16x148-ESD-C	70	M16	176	179	148	28	19	16	14	14000	250	270
324115-ESD	LVA-70-14-SST-M16x168-ESD-C	328115-ESD	LVA-70-14-AS-SST-M16x168-ESD-C	70	M16	196	199	168	28	19	16	14	14000	277	297
324121-ESD	LVA-80-14-SST-M8x43-ESD-C	328121-ESD	LVA-80-14-AS-SST-M8x43-ESD-C	80	M8	76	79	43	33	24	14	14	16000	84	110
324125-ESD	LVA-80-14-SST-M8x68-ESD-C	328125-ESD	LVA-80-14-AS-SST-M8x68-ESD-C	80	M8	101	104	68	33	24	14	14	16000	96	122
324221-ESD	LVA-80-14-SST-M10x43-ESD-C	328221-ESD	LVA-80-14-AS-SST-M10x43-ESD-C	80	M10	76	79	43	33	24	14	14	16000	93	119
324225-ESD	LVA-80-14-SST-M10x68-ESD-C	328225-ESD	LVA-80-14-AS-SST-M10x68-ESD-C	80	M10	101	104	68	33	24	14	14	16000	106	132
324231-ESD	LVA-80-14-SST-M10x98-ESD-C	328231-ESD	LVA-80-14-AS-SST-M10x98-ESD-C	80	M10	131	134	98	33	24	14	14	16000	120	146
324321-ESD	LVA-80-14-SST-M12x43-ESD-C	328321-ESD	LVA-80-14-AS-SST-M12x43-ESD-C	80	M12	76	79	43	33	24	14	14	16000	103	129
324325-ESD	LVA-80-14-SST-M12x68-ESD-C	328325-ESD	LVA-80-14-AS-SST-M12x68-ESD-C	80	M12	101	104	68	33	24	14	14	16000	121	147
324331-ESD	LVA-80-14-SST-M12x98-ESD-C	328331-ESD	LVA-80-14-AS-SST-M12x98-ESD-C	80	M12	131	134	98	33	24	14	14	16000	143	169
324421-ESD	LVA-80-14-SST-M14x68-ESD-C	328421-ESD	LVA-80-14-AS-SST-M14x68-ESD-C	80	M14	101	104	68	33	24	14	14	16000	144	170
324431-ESD	LVA-80-14-SST-M14x98-ESD-C	328431-ESD	LVA-80-14-AS-SST-M14x98-ESD-C	80	M14	131	134	98	33	24	14	14	16000	165	191
324441-ESD	LVA-80-14-SST-M14x148-ESD-C	328441-ESD	LVA-80-14-AS-SST-M14x148-ESD-C	80	M14	181	184	148	33	24	14	14	16000	248	274
324521-ESD	LVA-80-14-SST-M16x68-ESD-C	328521-ESD	LVA-80-14-AS-SST-M16x68-ESD-C	80	M16	101	104	68	33	24	16	14	16000	166	192
324525-ESD	LVA-80-14-SST-M16x108-ESD-C	328525-ESD	LVA-80-14-AS-SST-M16x108-ESD-C	80	M16	141	144	108	33	24	16	14	16000	220	246
324541-ESD	LVA-80-14-SST-M16x148-ESD-C	328541-ESD	LVA-80-14-AS-SST-M16x148-ESD-C	80	M16	181	184	148	33	24	16	14	16000	273	299
324561-ESD	LVA-80-14-SST-M16x168-ESD-C	328561-ESD	LVA-80-14-AS-SST-M16x168-ESD-C	80	M16	201	204	168	33	24	16	14	16000	300	326

\* The max static load is the value above which the load applied to the element may cause some plastic material breakage, in particular conditions of use. Obviously, a factor that takes into consideration the importance and the safety level of the specific application must be applied to this value.

# Data with no-slip disk mounted.

Conversion Table 1 mm = 0.039 inch	
D	
mm	inch
60	2.36
70	2.76
80	3.15
100	3.94
125	4.92

LVA-SST-ESD-C

LVA-AS-SST-ESD-C



Code	Description	Code	Description	D	d	L	L#	l	l1	h	s	Articulation ∅	Max. limit static load* [N]	⚖️	⚖️	#
324621-ESD	LVA-80-24-SST-M16x58-ESD-C	328621-ESD	LVA-80-24-AS-SST-M16x58-ESD-C	80	M16	101	104	58	43	24	24	24	18000	228	254	
324625-ESD	LVA-80-24-SST-M16x98-ESD-C	328625-ESD	LVA-80-24-AS-SST-M16x98-ESD-C	80	M16	141	144	98	43	24	24	24	18000	280	306	
324641-ESD	LVA-80-24-SST-M16x138-ESD-C	328641-ESD	LVA-80-24-AS-SST-M16x138-ESD-C	80	M16	181	184	138	43	24	24	24	18000	331	357	
324661-ESD	LVA-80-24-SST-M16x158-ESD-C	328661-ESD	LVA-80-24-AS-SST-M16x158-ESD-C	80	M16	201	204	158	43	24	24	24	18000	359	385	
324725-ESD	LVA-80-24-SST-M20x98-ESD-C	328725-ESD	LVA-80-24-AS-SST-M20x98-ESD-C	80	M20	141	144	98	43	24	24	24	18000	352	378	
324741-ESD	LVA-80-24-SST-M20x138-ESD-C	328741-ESD	LVA-80-24-AS-SST-M20x138-ESD-C	80	M20	181	184	138	43	24	24	24	18000	432	458	
324761-ESD	LVA-80-24-SST-M20x158-ESD-C	328761-ESD	LVA-80-24-AS-SST-M20x158-ESD-C	80	M20	201	204	158	43	24	24	24	18000	472	498	
324781-ESD	LVA-80-24-SST-M20x198-ESD-C	328781-ESD	LVA-80-24-AS-SST-M20x198-ESD-C	80	M20	241	244	198	43	24	24	24	18000	577	583	
324825-ESD	LVA-80-24-SST-M24x98-ESD-C	328825-ESD	LVA-80-24-AS-SST-M24x98-ESD-C	80	M24	141	144	98	43	24	24	24	18000	452	478	
324861-ESD	LVA-80-24-SST-M24x158-ESD-C	328861-ESD	LVA-80-24-AS-SST-M24x158-ESD-C	80	M24	201	204	158	43	24	24	24	18000	627	653	
324881-ESD	LVA-80-24-SST-M24x198-ESD-C	328881-ESD	LVA-80-24-AS-SST-M24x198-ESD-C	80	M24	241	244	198	43	24	24	24	18000	748	774	
325451-ESD	LVA-100-14-SST-M8x43-ESD-C	329451-ESD	LVA-100-14-AS-SST-M8x43-ESD-C	100	M8	76	79	43	33	24	14	14	18000	91	146	
325453-ESD	LVA-100-14-SST-M8x68-ESD-C	329453-ESD	LVA-100-14-AS-SST-M8x68-ESD-C	100	M8	101	104	68	33	24	14	14	18000	103	158	
325461-ESD	LVA-100-14-SST-M10x43-ESD-C	329461-ESD	LVA-100-14-AS-SST-M10x43-ESD-C	100	M10	76	79	43	33	24	14	14	18000	100	155	
325463-ESD	LVA-100-14-SST-M10x68-ESD-C	329463-ESD	LVA-100-14-AS-SST-M10x68-ESD-C	100	M10	101	104	68	33	24	14	14	18000	112	167	
325465-ESD	LVA-100-14-SST-M10x98-ESD-C	329465-ESD	LVA-100-14-AS-SST-M10x98-ESD-C	100	M10	131	134	98	33	24	14	14	18000	126	181	
325471-ESD	LVA-100-14-SST-M12x43-ESD-C	329471-ESD	LVA-100-14-AS-SST-M12x43-ESD-C	100	M12	76	79	43	33	24	14	14	18000	110	165	
325473-ESD	LVA-100-14-SST-M12x68-ESD-C	329473-ESD	LVA-100-14-AS-SST-M12x68-ESD-C	100	M12	101	104	68	33	24	14	14	18000	127	182	
325475-ESD	LVA-100-14-SST-M12x98-ESD-C	329475-ESD	LVA-100-14-AS-SST-M12x98-ESD-C	100	M12	131	134	98	33	24	14	14	18000	148	203	
325477-ESD	LVA-100-14-SST-M14X68-ESD-C	329477-ESD	LVA-100-14-AS-SST-M14X68-ESD-C	100	M14	101	104	68	33	24	14	14	18000	149	204	
325479-ESD	LVA-100-14-SST-M14X98-ESD-C	329479-ESD	LVA-100-14-AS-SST-M14X98-ESD-C	100	M14	131	134	98	33	24	14	14	18000	170	225	
325480-ESD	LVA-100-14-SST-M14X148-ESD-C	329480-ESD	LVA-100-14-AS-SST-M14X148-ESD-C	100	M14	181	184	148	33	24	14	14	18000	253	308	
325481-ESD	LVA-100-14-SST-M16x68-ESD-C	329481-ESD	LVA-100-14-AS-SST-M16x68-ESD-C	100	M16	101	104	68	33	24	16	14	18000	171	226	
325483-ESD	LVA-100-14-SST-M16x108-ESD-C	329483-ESD	LVA-100-14-AS-SST-M16x108-ESD-C	100	M16	141	144	108	33	24	16	14	18000	223	278	
325485-ESD	LVA-100-14-SST-M16x148-ESD-C	329485-ESD	LVA-100-14-AS-SST-M16x148-ESD-C	100	M16	181	184	148	33	24	16	14	18000	275	330	
325487-ESD	LVA-100-14-SST-M16x168-ESD-C	329487-ESD	LVA-100-14-AS-SST-M16x168-ESD-C	100	M16	201	204	168	33	24	16	14	18000	301	356	
325521-ESD	LVA-100-24-SST-M16x58-ESD-C	329521-ESD	LVA-100-24-AS-SST-M16x58-ESD-C	100	M16	101	104	58	43	24	24	24	25000	254	308	
325525-ESD	LVA-100-24-SST-M16x98-ESD-C	329525-ESD	LVA-100-24-AS-SST-M16x98-ESD-C	100	M16	141	144	98	43	24	24	24	25000	357	411	
325541-ESD	LVA-100-24-SST-M16x138-ESD-C	329541-ESD	LVA-100-24-AS-SST-M16x138-ESD-C	100	M16	181	184	138	43	24	24	24	25000	357	411	
325561-ESD	LVA-100-24-SST-M16x158-ESD-C	329561-ESD	LVA-100-24-AS-SST-M16x158-ESD-C	100	M16	201	204	158	43	24	24	24	25000	385	439	
325625-ESD	LVA-100-24-SST-M20x98-ESD-C	329625-ESD	LVA-100-24-AS-SST-M20x98-ESD-C	100	M20	141	144	98	43	24	24	24	25000	378	432	
325641-ESD	LVA-100-24-SST-M20x138-ESD-C	329641-ESD	LVA-100-24-AS-SST-M20x138-ESD-C	100	M20	181	184	138	43	24	24	24	25000	458	512	
325661-ESD	LVA-100-24-SST-M20x158-ESD-C	329661-ESD	LVA-100-24-AS-SST-M20x158-ESD-C	100	M20	201	204	158	43	24	24	24	25000	498	552	
325681-ESD	LVA-100-24-SST-M20x198-ESD-C	329681-ESD	LVA-100-24-AS-SST-M20x198-ESD-C	100	M20	241	244	198	43	24	24	24	25000	583	637	
325725-ESD	LVA-100-24-SST-M24x98-ESD-C	329725-ESD	LVA-100-24-AS-SST-M24x98-ESD-C	100	M24	141	144	98	43	24	24	24	25000	478	532	
325761-ESD	LVA-100-24-SST-M24x158-ESD-C	329761-ESD	LVA-100-24-AS-SST-M24x158-ESD-C	100	M24	201	204	158	43	24	24	24	25000	653	707	
325781-ESD	LVA-100-24-SST-M24x198-ESD-C	329781-ESD	LVA-100-24-AS-SST-M24x198-ESD-C	100	M24	241	244	198	43	24	24	24	25000	774	828	
326521-ESD	LVA-125-24-SST-M16x58-ESD-C	330221-ESD	LVA-125-24-AS-SST-M16x58-ESD-C	125	M16	125	128	58	67	46	24	24	28000	389	515	
326525-ESD	LVA-125-24-SST-M16x98-ESD-C	330225-ESD	LVA-125-24-AS-SST-M16x98-ESD-C	125	M16	165	168	98	67	46	24	24	28000	441	567	
326541-ESD	LVA-125-24-SST-M16x138-ESD-C	330241-ESD	LVA-125-24-AS-SST-M16x138-ESD-C	125	M16	205	208	138	67	46	24	24	28000	492	618	
326561-ESD	LVA-125-24-SST-M16x158-ESD-C	330261-ESD	LVA-125-24-AS-SST-M16x158-ESD-C	125	M16	225	228	158	67	46	24	24	28000	520	646	
326625-ESD	LVA-125-24-SST-M20x98-ESD-C	330325-ESD	LVA-125-24-AS-SST-M20x98-ESD-C	125	M20	165	168	98	67	46	24	24	28000	513	639	
326641-ESD	LVA-125-24-SST-M20x138-ESD-C	330341-ESD	LVA-125-24-AS-SST-M20x138-ESD-C	125	M20	205	208	138	67	46	24	24	28000	633	759	
326661-ESD	LVA-125-24-SST-M20x158-ESD-C	330361-ESD	LVA-125-24-AS-SST-M20x158-ESD-C	125	M20	225	228	158	67	46	24	24	28000	633	759	
326681-ESD	LVA-125-24-SST-M20x198-ESD-C	330381-ESD	LVA-125-24-AS-SST-M20x198-ESD-C	125	M20	265	268	198	67	46	24	24	28000	718	844	
326725-ESD	LVA-125-24-SST-M24x98-ESD-C	330425-ESD	LVA-125-24-AS-SST-M24x98-ESD-C	125	M24	165	168	98	67	46	24	24	28000	613	739	
326761-ESD	LVA-125-24-SST-M24x158-ESD-C	330461-ESD	LVA-125-24-AS-SST-M24x158-ESD-C	125	M24	225	228	158	67	46	24	24	28000	788	914	
326781-ESD	LVA-125-24-SST-M24x198-ESD-C	330481-ESD	LVA-125-24-AS-SST-M24x198-ESD-C	125	M24	265	268	198	67	46	24	24	28000	909	1035	

\* The max static load is the value above which the load applied to the element may cause some plastic material breakage, in particular conditions of use. Obviously, a factor that takes into consideration the importance and the safety level of the specific application must be applied to this value.

# Data with no-slip disk mounted.



Levelling elements and supports